

User Instructions
Cyrus III

Cyrus III Amplifier

Congratulations on the purchase of your *Cyrus III Amplifier*. This piece of equipment is a precision manufactured state-of-art product, constructed to the highest standards and specifications. This manual contains installation and operating instructions to enable the user to connect up and operate the amplifier correctly, thus ensuring the greatest satisfaction and long term use. This instruction manual is divided into eight sections.

- **Cautions**
- **Installation**
- **Operation**
- **Remote Control**
- **Additional Information**
- **Trouble Shooting**
- **Specifications**
- **Guarantee**

To enable you to make full use of the comprehensive facilities of the amplifier we suggest that you read these sections which will explain the fundamental operations of the unit.

CAUTION**POLARISED CONNECTOR (115V PRODUCTS ONLY)**

To prevent electrical shock, match wide blade of plug to wide slot and fully insert

Attention: Pour éviter les chocs électriques, introduire la lame la plus large de la fiche dans la borne correspondante de la prise et pousser jusqu'au fond.

Your *Cyrus III Amplifier* is factory set to operate from a fixed mains supply voltage, which is marked on a label at the rear of the unit. Before connecting, check that this voltage is the same as your mains supply, i.e.

230V Products	Voltage Range 220V-240V
115V Products	Voltage Range 110V-120V

UNPACKING

Always follow the instruction handbook and retain it in a safe place for future reference.

Before proceeding with installing the *Cyrus III Amplifier*, ensure that the following items are included in the accessory box:

- Instruction Manual
- Power Cable
- Remote Handset
- 4 Loudspeaker Plugs
- Guarantee Card

After removing these items, please retain the packing for future use.

LOCATION

Install the amplifier in a well ventilated location where it will not be exposed to high temperature or humidity.

Avoid installing the *Cyrus III Amplifier* in a location which is exposed to direct rays of the sun, or near to hot appliances or radiators. Placing and using the amplifier for long periods on heat-generating sources will affect performance and may damage the cabinet. Installation in a damp or dusty environment may result in malfunction or accident.

RE-LOCATING

The *Cyrus III Amplifier* is supplied ready for use in your location. Care has been taken to ensure that the power supply requirements are correctly set. Consult your Mission distributor to arrange for conversion of your *Cyrus III* should you move to another area with a different mains voltage supply.

PRECAUTIONS REGARDING INSTALLATION

It is important not to allow any liquid or foreign object fall into this unit. When routing the power cord avoid running it over or near sharp objects.

If the amplifier is not to be used for a long period of time, unplug the unit from the mains power supply.

This unit contains no user serviceable parts, therefore **never** remove any panels from the unit or attempt to service the unit. In the unlikely event of failure, please refer to qualified service personnel.

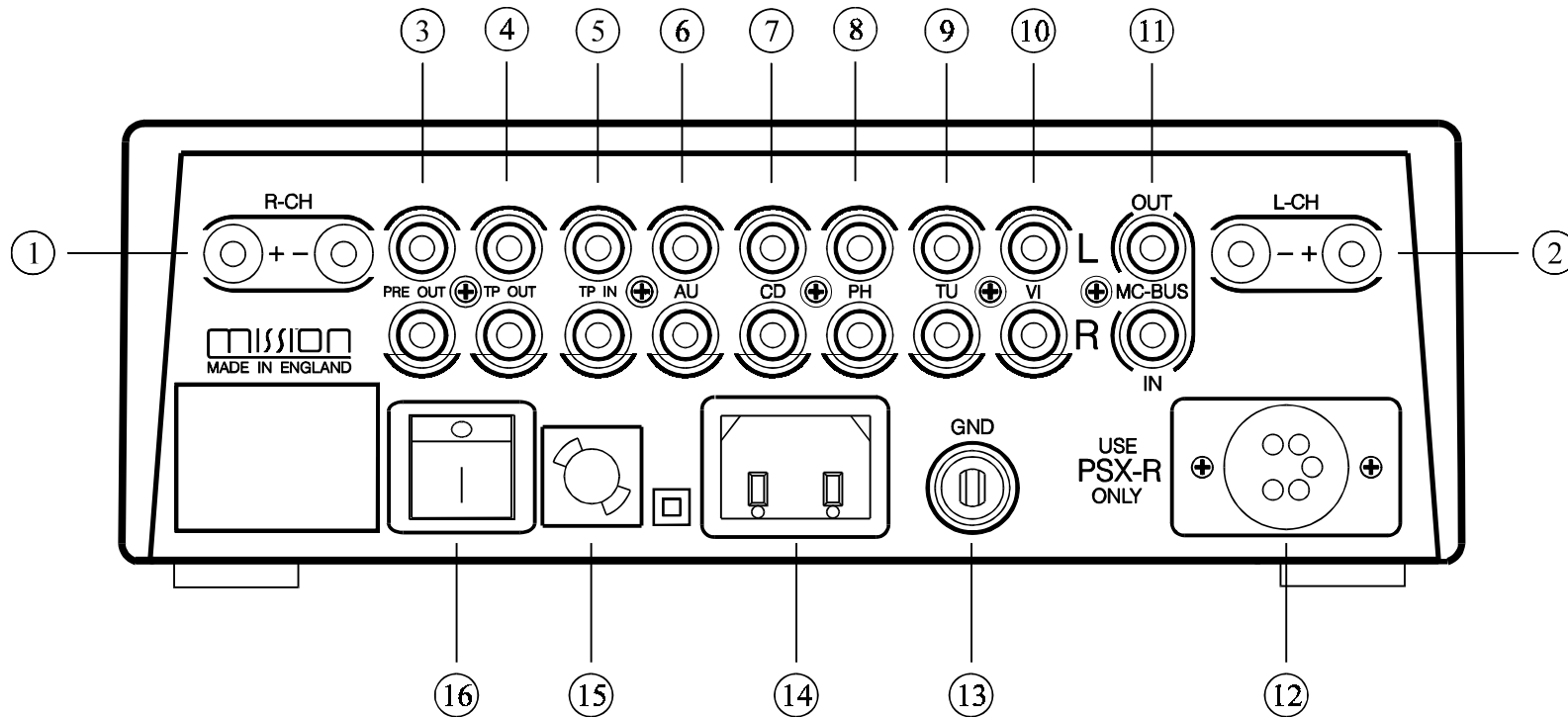

- 1. Right Speaker Output
- 2. Left Speaker Output
- 3. Pre-Amplifier Output
- 4. Tape Recorder Output
- 5. Tape Input
- 6. Aux Input
- 7. CD Input
- 8. Phono Input

- 9. Tuner Input
- 10. Video Input
- 11. MC-BUS System Connection
- 12. PSX-R Connection
- 13. Turntable Ground
- 14. Power Inlet
- 15. Mains Fuse
- 16. Power Switch

Fig.1 Amplifier (rear view)

POSITIONING THE UNIT

The *Cyrus III* may be positioned as a free standing unit or alongside another piece of audio equipment. Never stand the *Cyrus III* under another unit. This may adversely affect the efficient cooling of the *Cyrus III*. Never place the *Cyrus III* on a carpet or similar material which may hamper normal ventilation.

CONNECTING THE UNIT**The Mains Supply**

The moulded IEC connector of the mains lead supplied should be plugged in to the power inlet ⁽¹⁴⁾ on the rear of the unit.

The mains fuse ⁽¹⁵⁾ is located on the rear panel next to the power switch. It must only be replaced with the following types:

U.K. / Europe - 230V	T1A/20mm
N. America / Far East - 115V	T2A/20mm

In the U.K., the *Cyrus III* comes with the mains plug fitted. In the unlikely event that the plug fuse should need replacing ensure that it is only replaced with a 3 Amp Fuse.

IMPORTANT

NOTE TO USERS OF *PSX-R* WITH *CYRUS III*

In order to use a *PSX-R* regulated power supply with the *Cyrus III Amplifier*, certain internal adjustments must be made to the *Cyrus III* which can only be carried out by an authorised Mission distributor or his agent. Connection of the *PSX-R* to a *Cyrus III* which is not correctly adjusted will result in fault condition display on the *Cyrus III*. The *Cyrus III* fault indication system is fully described in the *Cyrus III* handbook.

Connecting a *PSX-R* Power Supply (Optional)

If a *PSX-R* is to be used with the *Cyrus III*, proceed to connect the umbilical cord of the *PSX-R* to the 5-pin Cannon input socket of the *Cyrus III*. When correctly fitted, the connector will latch into place in the socket. Note that when a *PSX-R* is in use, both the *PSX-R* power supply and the *Cyrus III* will require mains power.

Note:

For more details on the *PSX-R*, please refer to the *Cyrus PSX-R* Instruction Manual.

Connecting a Turntable

Connect the phono cable from the turntable to the phono input - PH ⑧. Be sure to follow colour coding of the plugs to keep left and right channels correctly ordered. If the turntable has a ground wire fitted, connect this to the Turntable ground connection ⑬ of the amplifier.

Note that the phono pre-amplifier of the *Cyrus III* is suitable for use with a pick-up cartridge of either moving magnet or high output moving coil design. A low output moving coil cartridge will require a step-up transformer or pre-amplifier to be used externally. Your dealer can advise if this is necessary.

Connecting other Inputs

Connect a phono cable between each system component and the rear panel sockets as marked on the rear panel diagram. At all times observe the colour coding of the phono cable for left and right channel identification. The *Cyrus III* provides for connection of a CD Player - CD ⑦, a tuner - TU ⑨, a video recorder or video disc player - VI ⑩, and an auxiliary input - AU ⑥.

The AU input can be used for connection of a wide variety of products such as a second CD player, tuner or VCR, an electronic keyboard, an organ or a second tape deck if only replay is necessary. Always check the technical

specification of these products before connecting to your *Cyrus III*. Consult your dealer if in doubt.

Connecting a Tape Recorder

Two phono cables are necessary for connection of a tape recorder when used. Firstly, connect a phono cable from the Output or Playback sockets of the tape recorder to the Tape Input - TP IN ⑤ of the *Cyrus III*. Then connect a second phono cable from the Input or Record sockets of the tape recorder to the Tape Record Output - TP OUT ④ sockets of the *Cyrus III*.

Connecting Loudspeakers

The left and right loudspeakers are connected to the rear panel sockets ① and ② of the *Cyrus III* respectively using the plugs provided. First, fit the plugs to the loudspeaker cables. Carefully note that the cable carries marking or colours for polarity, (+ and -) may also be marked for direction with an arrow. For correct operation, it is essential that the (+ and -) terminals of the amplifier are connected to the corresponding (+ and -) terminals of the loudspeakers. When fitting the plugs to the cables be sure to line up (+ and -) at each end. The loudspeaker plugs can now be fitted to the amplifier sockets.

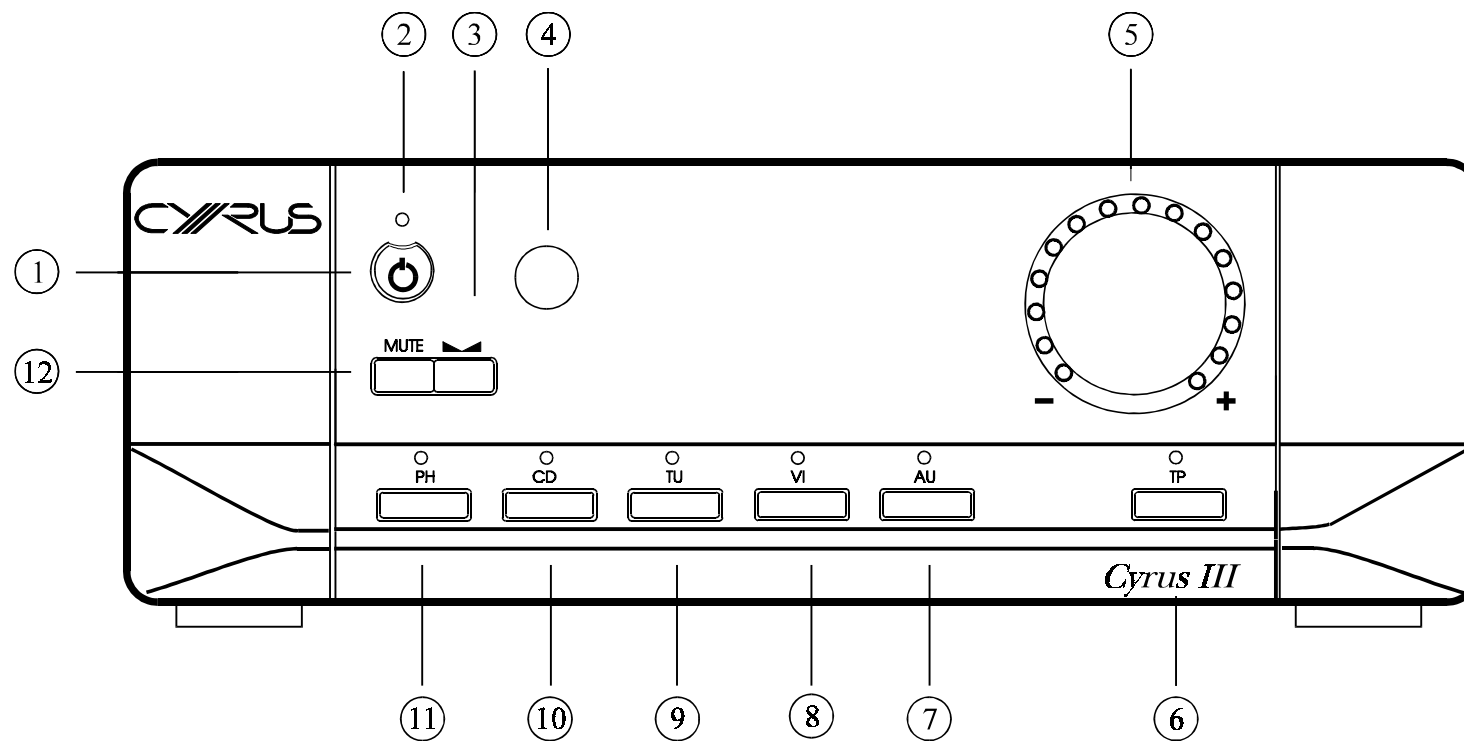

- 1. Standby Switch
- 2. Standby Light
- 3. Balance
- 4. Remote Eye
- 5. Volume Level
- 6. Tape

- 7. Auxiliary
- 8. Video
- 9. Tuner
- 10. CD
- 11. Phono
- 12. Mute

Fig. 2 Amplifier (front view)

POWER

The mains power switch ⑯ is located on the rear panel of the amplifier (refer to the rear panel drawing on page 4). This switch should be left on for normal operation, except when left unattended for a long period. In this case the mains power should then be switched off or the product disconnected from the AC supply.

Refer now to figure 2, front panel drawing on page 7.

When the amplifier is in regular use and power is permanently applied, the STANDBY key ① can be used for power control. The Standby light ② will show red when the amplifier is off and green when operating. The *Cyrus III* will also switch on when an input source ⑦-⑪ is selected.

SELECTING AN INPUT FOR LISTENING

The five input keys switch between selected input sources. These can be a turntable - PH, a CD player - CD, a tuner - TU, a video recorder or video disc player - VI and a spare auxiliary input - AU. When an input key is selected, the red indicator above the key will turn on.

RECORDING AND PLAYBACK

If the tape recorder connections are made according to the previous instruction in this manual, then you should be able to listen to a recording by selecting the Tape Monitor key - TP ⑥. The indicator above the TP key will now light in addition to the selected source. To cancel this, press the TP key again. Should your tape deck have a three-head facility, then you can use the TP key to monitor the recording quality directly from the third head, whilst recording.

You can record from a source by pressing the relevant Key ⑦-⑪ and following the recording instructions in your tape deck manual.

VOLUME AND BALANCE CONTROL

The rotary knob of the *Cyrus III* has a dual function of volume and balance control. The control is applied in precision steps of 1dB with 0.2dB channel balance accuracy throughout the volume range. The light ring around the knob performs different functions in each mode of operation.

*Remote Control Handset
as supplied with Cyrus III only*

Volume Control

In normal mode the rotary knob of the *Cyrus III* controls the volume in 1dB steps from its maximum level down to the minimum. The light ring around the knob is calibrated to give the correct loudness scale to the changes in the volume level. When the volume is set to the minimum level the first L.E.D. indicator on the light ring will be RED. The currently set volume is preserved when the unit is put into standby mode. Should the level be set abnormally high when standby is selected, this will be automatically adjusted down to a safer level on switch-on.

Balance Control

Your *Cyrus III* is equipped with a Balance control key ③ which is used to change the operation mode of the rotary knob to that of Left - Right Balance. When selected, the light ring will change function to work in "reverse - video" format with the unlit section indicating the position of L-R balance.



When in this mode, you can control the L-R balance by up to +/-4dB as well as switching one channel off completely when the control is turned to an extreme. The balance mode is automatically reset after 5 seconds of inactivity of the rotary knob. It can also be reset by pressing the balance key again.

Mute

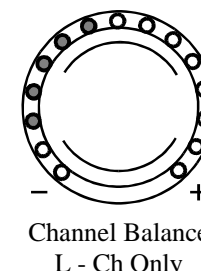
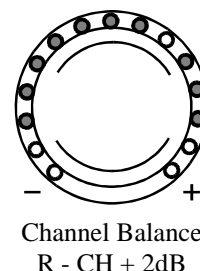
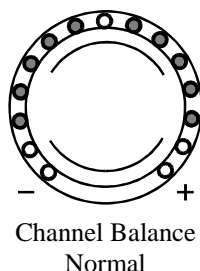
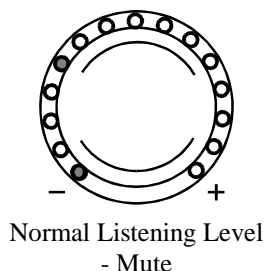
Pressing the Mute Key ⑫ will fade out the volume to minimum level without disturbing the existing setting. When muted the minimum level indicator light, RED will light as well as the existing GREEN light to show that the output is muted. Changing the volume knob or pressing the Mute key will reset the mute, fading in the original volume setting.

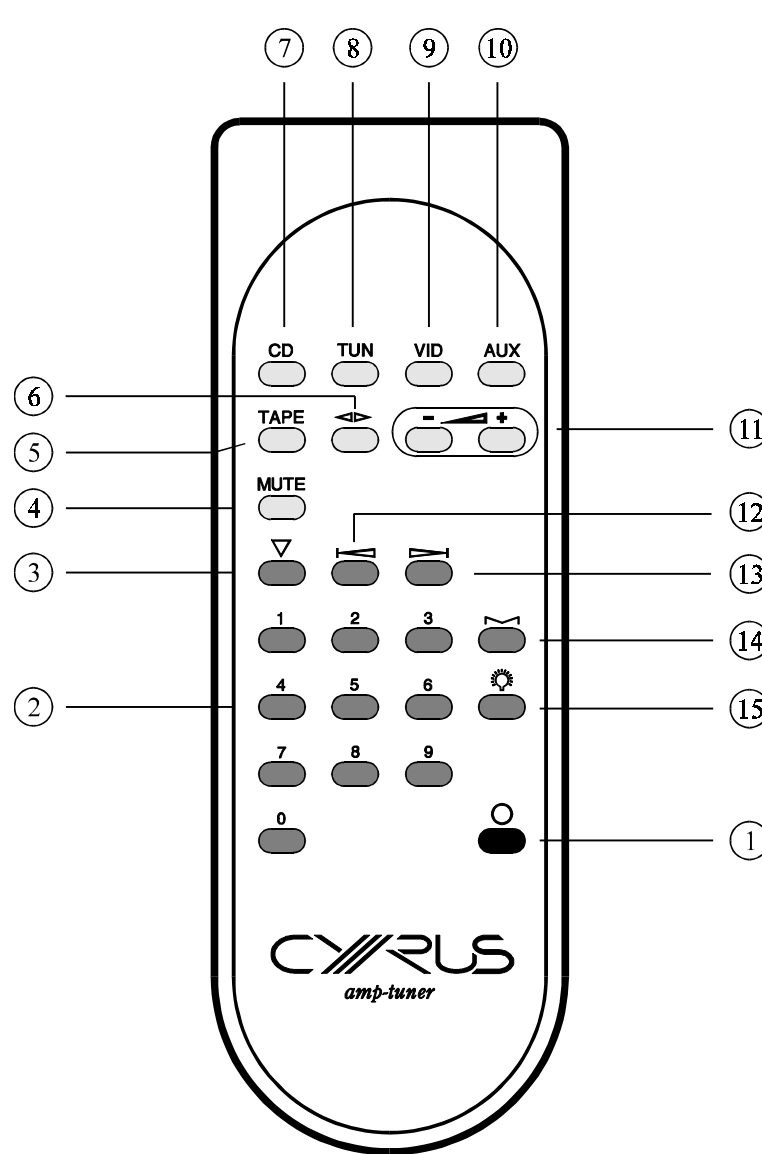



-  Controls for *Cyrus III Amplifier*
-  Controls for *Cyrus FM7 Tuner*
-  Power Off Control for *Cyrus III and Cyrus FM7*

- 1. Power Off
- 2. Numeric Keypad
- 3. Mono
- 4. Mute
- 5. Tape Monitor
- 6. Balance
- 7. CD Select
- 8. Tuner Select

- 9. Video Select
- 10. Aux Select
- 11. Volume Control
- 12. Seek Down
- 13. Seek Up
- 14. Store
- 15. Display

REMOTE OPERATION**Power**

Your *Cyrus III* may be turned on by selecting any Input Select Key (7) - (10) on the *Cyrus amp - tuner* handset. If an *FM7* is used, then pressing the Tuner Select Key - TUN (8) will also switch the tuner on. To switch the power off from the remote position, press the "Cyrus System Off" RED Key on the handset.

Cyrus III Controls

The remote control handset of the *Cyrus III* serves a dual purpose of controlling your amplifier as well as the *Cyrus FM7 Tuner* should you own one. The top three rows of keys on the handset replicate the front panel of the *Cyrus III* making it possible to have full control of the amplifier from a remote position.

FM7 Controls

Your *FM7's* functionality is greatly enhanced when using it with your *Cyrus amp - tuner* handset. The following paragraphs describe the *FM7* remote control functions in detail. Read the subsequent paragraphs if you own a *Cyrus FM7*.

Auto Tuning

In addition to the normal SEEK UP tuning facility available on the *FM7* front panel, the remote control handset provides the possibility of scanning down the broadcast band providing additional flexibility.

Preset Storage

Building onto the seven presets available on the front panel, the remote control handset gives access to 29 preset locations in total. To store a preset, select a station using AUTO or MANUAL tuning and press the STORE key (14). The preset digits on the display will flash prompting you to enter a two-digit preset location number. For location numbers under 9 the digit must be preceded by a zero.

Preset Selection

The numeric keypad of the handset enables direct entry of the preset location number. To select a preset enter a two-digit number up to 29. Exceptions to this are location numbers 3 to 9 which can be accessed by a single digit entry.

Mono Operation

The tuner may be forced into mono operation using the MONO key ③ on the handset. This is useful in cutting the background noise substantially when tuned to weak transmissions. This function may also be beneficial in improving quality of centre-image broadcasts such as news, sports, etc.

Should you wish to permanently receive a particular in MONO proceed as follows. Tune to the desired station and press the MONO key ③. The mono symbol '■' will be displayed on the front panel in place of the stereo symbol '○'. Press the STORE key ⑭ and dial in the preset location number as required.

Display Control

The DISPLAY key ⑮ on the handset can be used to switch the display of the *FM7* off should this be preferred. Pressing this key again restores the display to its normal mode. Switching the display off reduces the power consumption of the unit and eliminates the digital traffic related to the display update function. This can improve the overall quality of reception without adversely affecting the normal functions of your *FM7*.

KNOW YOUR CYRUS III**Power**

- When first powered up from the mains switch on the rear panel, the *Cyrus III* will run a self-test, checking the internal functions and all the front panel indicators in sequence. After completion of this cycle the amplifier will revert to Standby mode. When first switched on from standby the CD input is automatically selected and the volume is set to minimum.
- When set to Standby the front panel settings for input selection and Volume/Balance will be retained until next used. If the unit is put in standby mode while set to abnormally high volume levels, the *Cyrus III* will power on at the safe level of -15dB when next switched on.
- When switched to Standby, the power amplifier section of the *Cyrus III* is shut down to ensure minimal power consumption and reduced heat generation.
- If other Cyrus products are used with the *Cyrus III*, they can be connected via the MC-BUS as shown on page 15. This will ensure that the power ON/OFF will function in unison between all Cyrus products, locally as well as via the remote control handset. For

example, if the tuner input - TUN of the *Cyrus III* is selected, then the *FM7* tuner will automatically turn on. Conversely if the Standby key on the *Cyrus III* is pressed, then all Cyrus products connected via the MC-BUS will turn off.

- The *Cyrus III* runs at a high quiescent current setting to ensure deep operation into class AB. This naturally results in the enclosure to be warm to the touch and therefore should not be a cause for concern.

Volume and Balance

- The volume control system of your *Cyrus III* is a precision 1dB - step attenuator design which is musically transparent. One major advantage of this design is its absolute accuracy, which unlike conventional volume pots maintains +/-0.1dB tolerance *throughout* 63 steps of attenuation available.
- The volume setting of your *Cyrus III* is achieved independently for the Left and Right channels. The L-R channel balance can therefore be controlled by applying an offset to the attenuation of one channel with respect to the other with the same degree of precision. The channel balance is maintained within +/- 0.2dB across the full volume control range.

Signal Processors

- A multitude of signal/sound processing components such as Dolby Pro-Logic sound processors may be used with the *Cyrus III* by connection inside the "Tape Loop" of the amplifier. In this case the tape recorder is normally connected to the processor instead. For detailed connectivity refer to the relevant component's manual.

Bi-amping / Tri-amping

- The buffered pre-amplifier output of the *Cyrus III* may be used in conjunction with added power amplifier blocks to upgrade your loudspeaker system through Bi-amping or Tri-amping. In this case you should check that the sensitivity of the power amplifier modules are compatible with the output level of the *Cyrus III*.

External Regulated Power Supply - *PSX-R*

- Addition of a *PSX-R* which is a highly regulated DC power supply will upgrade the sonic performance of your *Cyrus III* as well as enhancing its current drive ability into difficult loudspeaker loads. Should you decide to add this optional extra to your system, be sure to have your *Cyrus III* converted by your dealer or an authorised Cyrus Service Organisation.

- When *Cyrus III* / *PSX-R* combination is installed all analogue and signal related sections of the *Cyrus III* are powered from this clean and highly stable power source, while the remaining power requirements are supplied internally. This technique ensures complete isolation of the sensitive analogue sections from the control side as well as the AC mains-borne noise and power supply ripple which of course, enhances the delicacy and transparency of the reproduced music programme.

MC-BUS System Connection

- This is an optional connection via the MC-Bus sockets ⑪ (see rear panel drawing on page 4), which can provide unified power control of a complete *Cyrus* system from your *Cyrus III*. The MC-Bus connections should be wired as a 'loop' using single RCA phono interconnects. The diagram on the next page shows a typical *Cyrus* system of *Cyrus DAD7*, *Cyrus FM7*, *Cyrus III* and *Cyrus Power* with such an MC-Bus loop connected. Referring to this diagram, connect the first cable between the MC-Bus output of the *Cyrus III* and the MC-Bus input of the next *Cyrus* component. Continue to wire each product MC-Bus output to the next input, finally returning to the *Cyrus III* input to complete the loop.

Operating a system with MC-Bus connected

Cyrus III Amplifier

ADDITIONAL INFORMATION

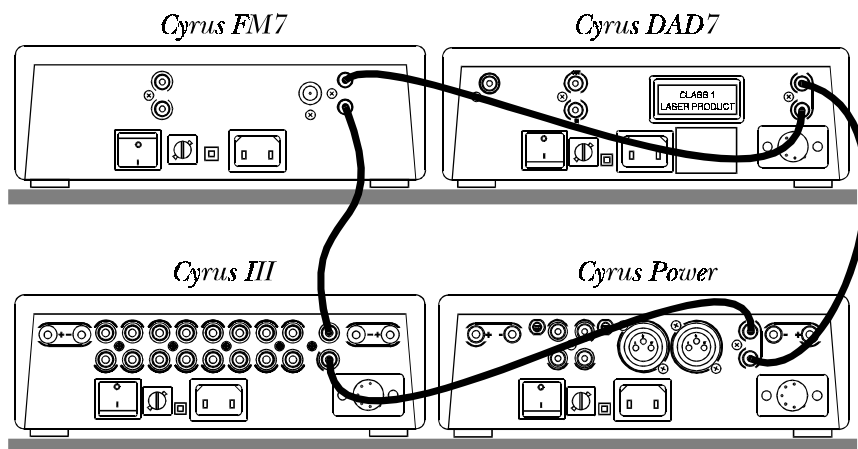

- When the above connections have been made it will now be possible to control the power function of the entire system from the *Cyrus III*, either from the front panel or by remote control. Selecting 'CD' from the *Cyrus III* front panel will then switch on the *Cyrus III*, the *Cyrus Power* and the *Cyrus DAD7* CD player. When the *Cyrus III* is set to Standby, all system components will also switch off.
- Another important function of the MC-Bus system is to enable Micro-processor controlled testing and calibration to be applied during the production phase of the *Cyrus* range of products. Using the MC-Bus all possible tests relating to the correct operation of the system are performed in a relatively short period of time. Such rigorous tests are only possible with the aid of this proprietary communication bus system

which ensures consistency and quality levels hitherto impossible to achieve in an audio product of this price range.

AMPLIFIER MAINTENANCE

There are no user serviceable parts in the *Cyrus III* so there is no reason to remove any of the panels. After disconnecting the mains power supply, the cabinet may be cleaned using a chamois leather, slightly moistened with water. DO NOT use cleaning agents containing alcohol, spirits, ammonia or abrasives.

THE MISSION/CYRUS GROUP MANUFACTURE

- Loudspeakers
- Loudspeaker Stands
- Loudspeaker Cables
- Compact Disc Players
- D-to-A Converters
- Amplifiers
- Tuners
- Home Theatre Processors
- Regulated Audio Power Supplies
- Isoplat (Vibration Isolation Platform)

TROUBLESHOOTING GUIDE

If you suspect that your *Cyrus III* is not operating to specification please read through this section before returning the amplifier to your local dealer.

No Sound from either Speaker

- Check that the amplifier is on. Green power light should be "ON".
- Check that the amplifier responds to different front panel commands.
- Check that the MUTE light on the volume control light ring is "OFF".
- Check that the relevant programme source is selected and is working. For example the CD Player is playing.
- Check that the Tape Monitor is not selected inadvertently, RED light above the TP key is "OFF".
- Check that the loudspeakers are not inadvertently disconnected.
- Check that the installation is correct according to the installation guide in this booklet.
- Check that there is not fault indication on your *Cyrus III* front panel. If so refer to the next section.

No Sound from one Speaker

- Check the Balance Control is not set to left or right limits.
- If your loudspeakers are fitted with protection fuses, check that the fuse is intact.
- Check the interconnect cable integrity on the rear panel and at source. If possible use another interconnect cable.
- Check the speaker cable connection integrity of the missing channel.

If the problem persists proceed as follows:

- Change the programme source using the suspected interconnect cable and check that the problem still exists. If the fault is removed by doing this then the original source is at fault.
- Interchange the left and right connection of the interconnect cable at SOURCE. If the missing channel switches over then there is a problem in one channel of the source or the interconnect. If the sound disappears totally then there may be two problems present in your system.
- Change over the left and right channels of your loudspeaker on the *Cyrus III* rear panel. If the problem stays in the same channel, then there is a

fault in the loudspeaker cable or the loudspeaker. Now switch the cable at the loudspeaker end and if the problem switches then the loudspeaker is faulty, otherwise it is the loudspeaker cable which may be defective.

Note:

Be sure to restore the system to its original configuration after completion of the above series of tests.

Spurious Sounds from the Loudspeakers

If you experience strange or unnatural noises from your system proceed as follows:

- Select another source to ensure that this is not a common problem. If the problem remains switch the *Cyrus III* off at the rear panel and turn it on again after a few seconds.
- If the problem is limited to a single source, check the integrity of the interconnection to the source and in the case of a phono turntable, check that the phono ground wire is secured at the rear panel of the *Cyrus III*.

FAULT INDICATION SYSTEM

The *Cyrus III* has a unique fault indication system, built in to help you to diagnose the possible cause of a problem. All fault indications are presented by the Standby light on the front panel of your *Cyrus III*.

FAULT INDICATION AT FIRST INSTALLATION**Flashing RED**

- This indicates that the *Cyrus III* has been adjusted for use with a *PSX-R* power supply, but a *PSX-R* has not been connected correctly. In this case, check that the *PSX-R* umbilical cord is connected to the rear panel *PSX-R* socket and that the mains power is connected securely to both products. If the connections are in order and the indication persists, return the unit(s) to your Mission distributor.

Flashing GREEN

- This indicates that a *PSX-R* power supply has been connected to a *Cyrus III* without the correct preparation for *PSX-R* use. In this case, remove the *PSX-R* cable and re-test the *Cyrus III*. If the *Cyrus III* functions correctly, return the amplifier to a Mission distributor for *PSX-R* adjustment.

FAULT INDICATION WHEN IN USE**Flashing GREEN / YELLOW**

- This indicates an overload condition in at least one channel. If the problem is of a temporary nature (for example excessive volume setting), normal operation will resume after four seconds. If the fault indication persists, there may be a problem with the loudspeakers or their connections. In this case, switch off the power at the rear of the *Cyrus III* and disconnect the speaker cables from the rear panel. If the fault indication has now cleared, check the loudspeakers, cables and plugs carefully for loose strands of wire which may cause a short circuit.

Flashing RED

- This indicates an internal problem with the *Cyrus III* or *PSX-R* (where used). If the problem does not clear when the amplifier power is reset, return the unit(s) to your Mission distributor for checking.

Flashing GREEN

- This indicates a fault reported from the *PSX-R*. In this case, switch off the power to both the *Cyrus III* and the *PSX-R* and switch on again. If the problem does not clear, return both units to your Mission distributor for checking.

AUDIO PERFORMANCE

Input Sensitivity	Line	200mV
(50W/8Ω)	Phono	2.75mV
Input Impedance	Line	22kΩ
	Phono	47kΩ
		+50pF
Volume Control Accuracy		+/-0.1dB
0dB to - 63dB		
Channel Balance		+/-0.2dB
0dB to -63dB		
Frequency Response (-3dB)... Line.....		2Hz, 80kHz
RIAA accuracy	Phono	+/-0.2dB
Signal to Noise Ratio	Line	98dBA
(A-WTD)	Phono	80dBA
Power Output	8 Ohms	50W
(both channels driven)	4 Ohms	70W
THD+N (PRE - AMP)	Line	0.004%
1kHz	Phono	0.03%

THD+N (AMP)		
(both channels driven)	8 Ohms	0.02%
(1kHz half power).....	4 Ohm.....	0.03%

POWER SUPPLY

Voltage

See the plate attached to the rear of unit

Power Consumption

Standby	(12W)
ON (No Load).....	(23W)
ON (2 x 50W/Ch)	(185W)

Safety Requirements.....IEC 65

ENCLOSURE

Dimensions (WxHxD).....	215 x 75 x 365 mm
Weight.....	4.6Kg
Material.....	Magnesium alloy and Aluminium alloy

The company reserves the right to change this specification without prior notice.

Part No. AM-MANUL/Iss.02-9511 File:7AEN5B11.WIM

This guarantee only becomes effective if the guarantee card enclosed is completed by the Dealer and the purchaser and returned to MISSION or Distributor within 8 days of purchase.

This guarantee excludes:

- i) All damage caused through accident, misuse, wear and tear, neglect or through incorrect installation, adjustment or repair by unauthorised personnel.
- ii) Liability for damage or loss occurring in transit to or from the purchaser.

Claims under this guarantee must, whenever possible, be made through the Dealer from whom the equipment was purchased or if that is not convenient, through another authorised MISSION/CYRUS dealer.

MISSION shall not be liable for any consequential damage, loss or injury whatsoever, arising from or in conjunction with this equipment.

The cost of carriage (to or from the Dealer) shall be borne by the purchaser.

This guarantee is personal to the original Purchaser and is not transferable.

If equipment is found on examination to comply with the published specification, MISSION reserves the right to make a charge for examination and for return carriage.

No Dealer or Distributor has any authority to vary the terms of this guarantee.

Any unauthorised servicing will result in loss of guarantee.

We strongly recommend that you retain the sales receipt for your *CYRUS* equipment in case of any warranty claim.

The above conditions do not affect your statutory rights as a consumer.

